



OWNER'S MANUAL

SINAQUA SOUPER (11/7/4 QT)



TABLE OF CONTENTS

- 1. REVISION HISTORY 4
- 2. IMPORTANT SAFETY INSTRUCTIONS 5
 - 2.1 General Safety Information 5
 - 2.2 Grounding Instructions 7
 - 2.3 Power Cord Replacement 7
 - 2.4 Protective Earth (Ground) Symbol 7
 - 2.5 Equipotential Bonding Symbol 7
- 3. SPECIFICATIONS 8
 - 3.1 Performance 8
 - 3.2 Dimensions: Countertop 8
 - 3.3 Dimensions: Drop-In 9
 - 3.4 Certifications 11
 - 3.5 Electrical Specifications 11
- 4. INSTALLATION 12
 - 4.1 Unpacking Instructions 12
 - 4.2 Souper and Control Box: Drop-In 12
- 5. OPERATION 14
 - 5.1 Control Box 14
 - 5.2 4 Qt Drop-In: LED Operation 15
- 6. CLEANING 16
- 7. TROUBLESHOOTING 17
- 8. NORTH AMERICA LIMITED WARRANTY: NON-PORTABLE 18
- 9. NORTH AMERICA LIMITED WARRANTY: PORTABLE 21

For further information, call

800.908.8726

or

+1 214.379.6000

1. REVISION HISTORY

Revision	Revision Date	By	Revision Description
A	03-Feb-26	BA	<ul style="list-style-type: none">• New template, updated version 105289 Rev E• Updated dimensions for the 4-, 7-, and 11- qt units• Updated graphics

2. IMPORTANT SAFETY INSTRUCTIONS

This manual provides essential information for the installation, operation, maintenance, and service of this oven. Information and specifications are subject to change without notice. Retain for future reference.

⚠ WARNING: When operating this oven, strictly adhere to the following safety precautions to reduce the risk of burns, electric shock, fire, injury, or damage to the oven or property near the oven.

2.1 General Safety Information

- ✓ Read all instructions before using this appliance.
- ✓ To ensure proper use of the appliance, read all parts of this manual carefully and store it safely.
- ✓ This appliance must be grounded. Connect only to a properly grounded outlet. Refer to the [Grounding Instructions](#) section.
- ✓ Install or locate this appliance only in accordance with the provided installation instructions.
- ✓ This appliance should be serviced by qualified service personnel only. Contact the nearest authorized service facility for examination, repair, or adjustment.
- ✓ Keep away from gas and electric ranges and open flames.
- ✓ Use this appliance only for its intended uses as described in this manual.
- ✓ This unit is designed to hold and reheat food and is not intended for laboratory or industrial use.
- ✓ This appliance is designed for professional use. Only allow qualified or duly instructed personnel to use.
- ✓ Always monitor the appliance during operation.
- ✓ In the event of a failure, breakage, or irregular function, switch the appliance off and disconnect from the power supply.
- ✓ Only use induction crockery and induction trays recommended by the manufacturer (IEC60335-2-49/A1).
- ✓ Users with heart pacemakers should consult with the manufacturer (IEC60335-2-49/A1).
- ✓ This appliance is not to be used by children or persons with reduced physical, sensory, or mental capabilities, or a lack of experience and knowledge, unless a responsible person has given them supervision or instruction.
- ✓ Keep children aged 8 years and younger away from the equipment during use. Children 8 years and older should use the equipment only with appropriate adult supervision.

DO NOT perform the following:

- ✘ Allow children to clean or perform maintenance on this equipment without adult supervision.
- ✘ Use any accessories or attachments that are not recommended by the manufacturer. Use of unapproved accessories may cause injuries and void the warranty.
- ✘ Strike or damage the appliance. Dropping the unit can damage the internal components or crack it, voiding your warranty. If the appliance SinAqua Souper™ becomes cracked, unplug the unit immediately and do not use it
- ✘ Operate this appliance if it has a damaged cord or plug, is not working properly, has been damaged, or dropped. Refer to the [Power Cord Replacement](#) section.
- ✘ Store this appliance outdoors, upside down, or in a non-climate-controlled environment.
- ✘ Use this appliance near water (e.g., a kitchen sink, a wet basement, or a swimming pool).
- ✘ Immerse the cord or plug in water.
- ✘ Let the cord hang over the edge of a table or counter.
- ✘ Place the cord near heated surfaces.
- ✘ Use a water jet for cleaning. Refer to the [Cleaning](#) section for more information.
- ✘ Place metallic objects, such as kitchen utensils and cutlery, on the induction tray within the zones provided for induction crockery, as they may become hot (IEC60335-2-49/A1).

2.2 Grounding Instructions

This appliance must be grounded. In the event of an electrical short circuit, grounding reduces the risk of electric shock by providing a path for the electric current. Consult a qualified electrician or serviceman if uncertain about the ability to follow grounding instructions or if doubt exists as to whether the appliance is properly grounded.

⚠ WARNING: Improper grounding can result in risk of electric shock.

- ✘ Do not use an extension cord. If the power cord is too short, have a qualified electrician or serviceman install an outlet near the appliance.
- ✘ Never cut, remove, or disable the electrical (ground) connection from the plug.

2.3 Power Cord Replacement

If the power cord is damaged, it must be replaced by the manufacturer, its service agent, or a similarly qualified person.

⚠ WARNING: If the oven is unplugged during service or maintenance, the user must always be able to access and see the plug to ensure that the oven remains unplugged. The plug must remain near the oven and cannot be placed behind another appliance or in another room.

2.4 Protective Earth (Ground) Symbol



This symbol identifies the terminal intended for connecting an external conductor to protect against electric shock in case of a fault, or the terminal of a protective earth (ground) electrode.

2.5 Equipotential Bonding Symbol



This symbol identifies terminals that, when connected, bring the various parts of an equipment or system to the same potential, not necessarily the earth (ground) potential, e.g., for local bonding.

3. SPECIFICATIONS

3.1 Performance

The SinAqua™ Souper™ is a portable countertop unit from CookTek designed to rethermalize and precisely hold food. Featuring a forward-thinking design and high-contrast, easy-to-use capacitive touch controls, the SinAqua™ Souper™ can heat liquid foods from a chilled, unfrozen state through the food safety danger zone in as little as 45 minutes. After rethermalization, food is maintained at a precise temperature within a selectable range of 140–200 °F (60–95 °C). Using CookTek inductive heating technology, the SinAqua™ Souper™ heats food evenly without scorching, holds food twice as long as steam wells, and uses less than half the energy. It eliminates the maintenance and plumbing requirements of traditional soup warmers.

3.2 Dimensions: Countertop

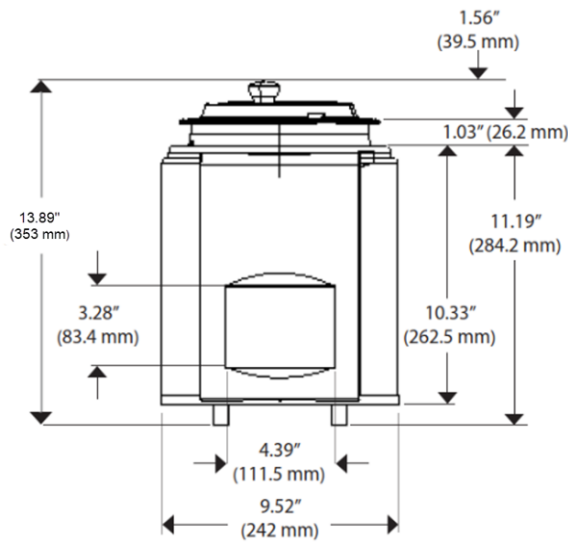

Figure 3-1: 4 Qt Freestanding SinAqua Souper

DIMENSIONS		
Unit Height	13.89"	353 mm
Width	9.52"	242 mm
Depth	10.22"	260 mm
Weight	9.50 lb	4.3 kg
Packaged Weight	12 lb	5.4 kg

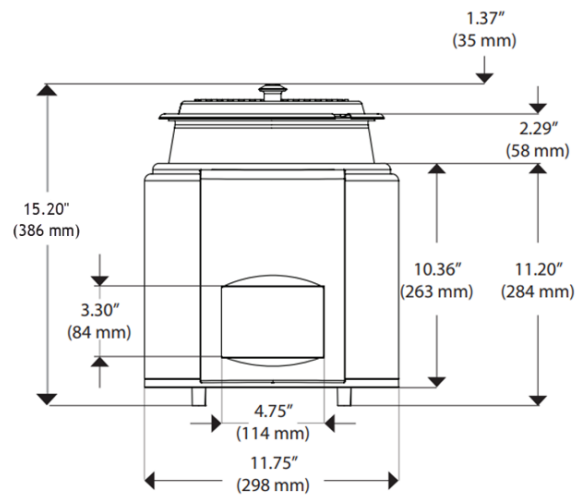

Figure 3-2: 7 Qt Freestanding SinAqua Souper

DIMENSIONS		
Unit Height	15.20	386 mm
Width	11.75"	298 mm
Depth	12.21"	310 mm
Weight	11.05 lb	5.0 kg
Packaged Weight	17 lb	7.7 kg

SPECIFICATIONS

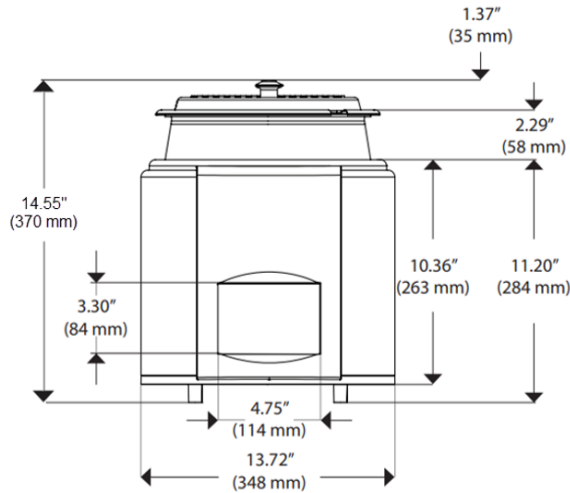

Figure 3-3: 11 Qt Freestanding SinAqua Souper

DIMENSIONS		
Unit Height	14.55"	370 mm
Width	13.72"	348 mm
Depth	14.27"	362 mm
Weight	12.90 lb	5.9 kg
Packaged Weight	17 lb	7.7 kg

3.3 Dimensions: Drop-In

The SinAqua Soupers are designed to be used exclusively with CookTek- specific tureens and lids. The compatible options include:

- 4 qt (302478)
- 7 qt (302409)
- 11 qt (302408)

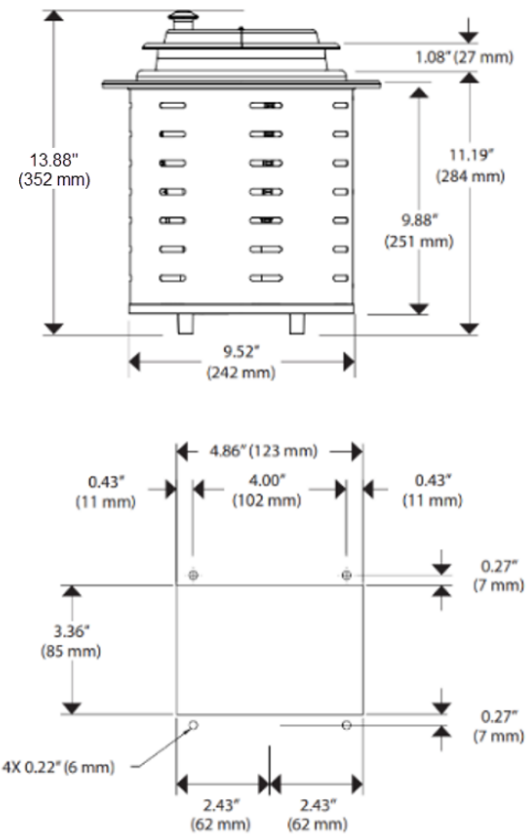

Figure 3-4: 4 Qt Drop-In SinAqua Souper

DIMENSIONS		
Unit Height	13.88"	352 mm
Width	11.78"	299 mm
Depth	9.75"	248 mm
Weight	9.75 lb	4.4 kg
Packaged Weight	13 lb	5.9 kg

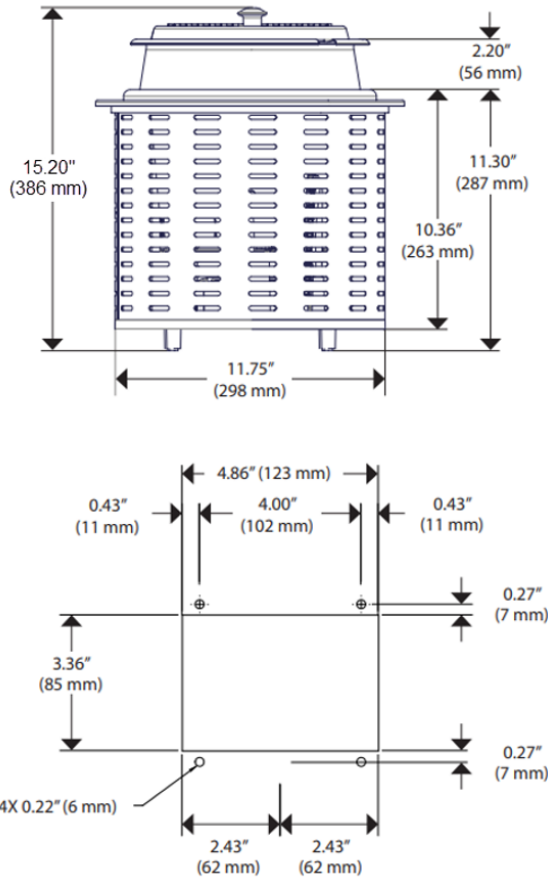

Figure 3-5: 7 Qt Drop-In SinAqua Souper

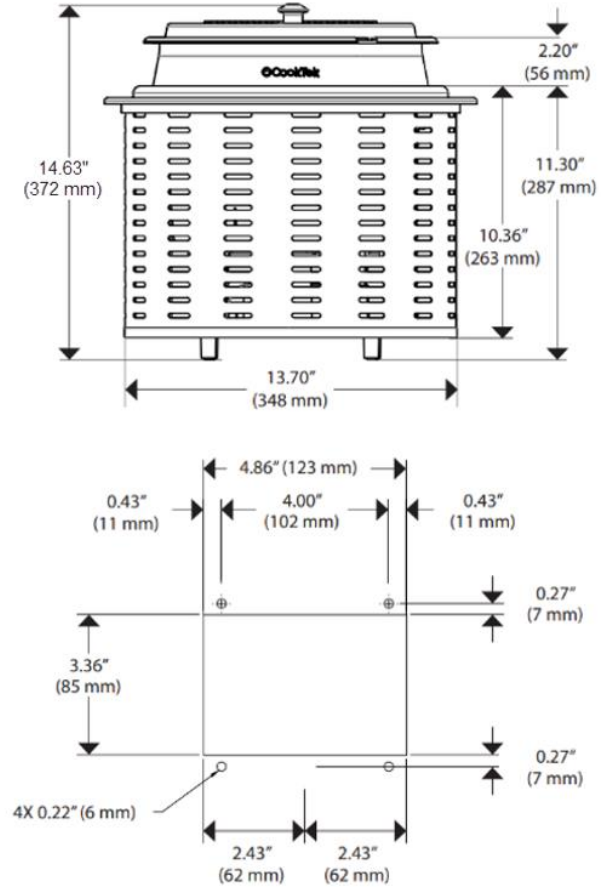

Figure 3-6: 11 Qt Drop-In SinAqua Souper

DIMENSIONS		
Unit Height	15.20"	386 mm
Width	13.44"	341 mm
Depth	12"	305 mm
Weight	11.55 lb	5.2 kg
Packaged Weight	17 lb	7.7 kg

DIMENSIONS		
Unit Height	14.63"	372 mm
Width	16.10"	409 mm
Depth	14"	356 mm
Weight	13.75 lb	6.2 kg
Packaged Weight	17 lb	7.7 kg

SPECIFICATIONS

3.4 Certifications



3.5 Electrical Specifications

The SinAqua Souper™ must be connected to a grounded, single-phase outlet. Check the nearby data and verify the unit's rating plate to confirm the correct voltage and wattage. Voltages below the specified range can cause reduced power and slower heating times.

4 Qt Units	
United States/ Canada (208 V)	100–120 V, 50/60 Hz, 3.5A, 400 W
United States/ Canada (240 V)	100–120 V, 50/60 Hz, 2A, 400 W
UK/Middle East	100–120 V, 50/60 Hz, 2A, 400 W
International	100–120 V, 50/60 Hz, 2A, 400 W
Australia	100–120 V, 50/60 Hz, 2A, 400 W
South Africa	100–120 V, 50/60 Hz, 2A, 400 W
Israel	100–120 V, 50/60 Hz, 2A, 400 W

7 and 11 Qt Units	
United States/ Canada (208 V)	100–120 V, 50/60 Hz, 7A, 800 W
United States/ Canada (240 V)	200–240 V, 50/60 Hz, 4A, 800 W
UK/Middle East	200–240 V, 50/60 Hz, 4A, 800 W
International	200–240 V, 50/60 Hz, 4A, 800 W
Australia	200–240 V, 50/60 Hz, 4A, 800 W
South Africa	200–240 V, 50/60 Hz, 4A, 800 W
Israel	200–240 V, 50/60 Hz, 4A, 800 W

SPECIFICATIONS

4. INSTALLATION

Install or locate this appliance only in accordance with the instructions below. It is the installer's responsibility to comply with all federal, state, and local codes. Any installation that does not meet the specifications discussed in this manual automatically voids the product warranty.

Note: The SinAqua Souper™ operates without water and does not use steam to heat food. If water enters the chamber where the tureen is placed, whether during operation or cleaning, it will drain below the Souper™ unit.

4.1 Unpacking Instructions

1. Remove the SinAqua Souper™ from its packaging.
2. If unpacking a drop-in unit, remove the mounting ring and control box from the packaging.
3. Before discarding, check the packaging thoroughly for accessories and literature.
Note: Keeping the packaging is recommended in case the oven may be shipped to another location.
4. Secure the power cord firmly before plugging in the unit and before starting operation.

4.2 Souper and Control Box: Drop-In

1. Connect the micro-USB cable to the Souper unit.

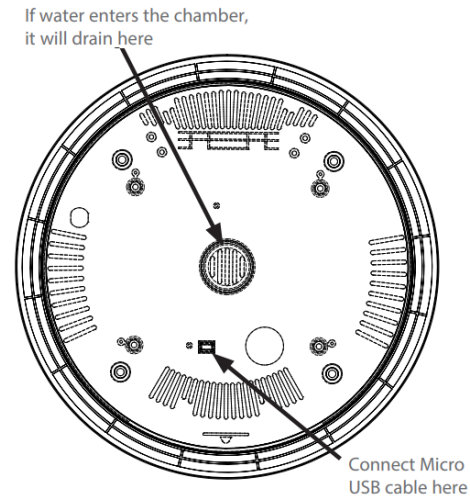

2. Install the Souper™ using the following surface cutout dimensions:
 - 4 qt: 9.75" (248 mm) diameter hole
 - 7 qt: 12" (305 mm) diameter hole
 - 11 qt: 14" (356 mm) diameter hole
3. Install the stainless-steel overlay if it was included with your order.

Stainless Steel Overlay
(accessory only; not standard item)

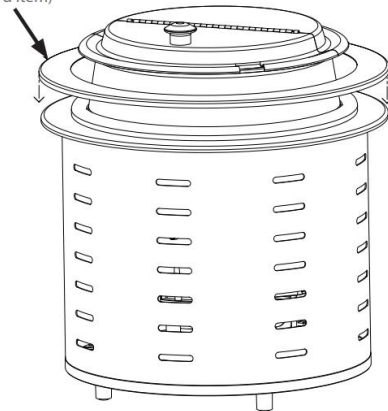

INSTALLATION

4. Connect the other end of the micro-USB cable to the control box.

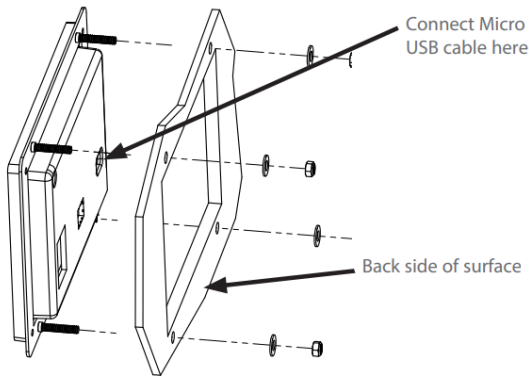

5. Install the control box using the cutout dimensions.

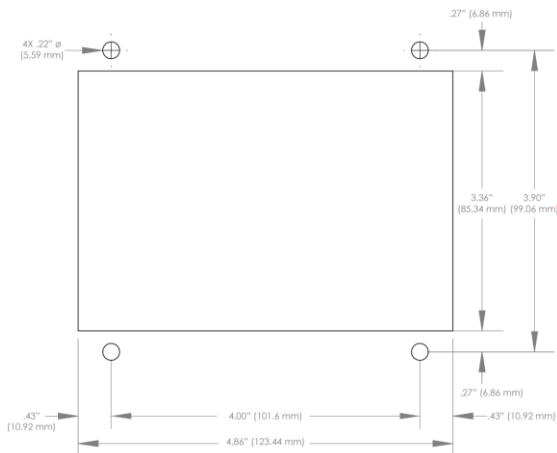

6. Plug in the Souper™ to the power source.

5. OPERATION

5.1 Control Box

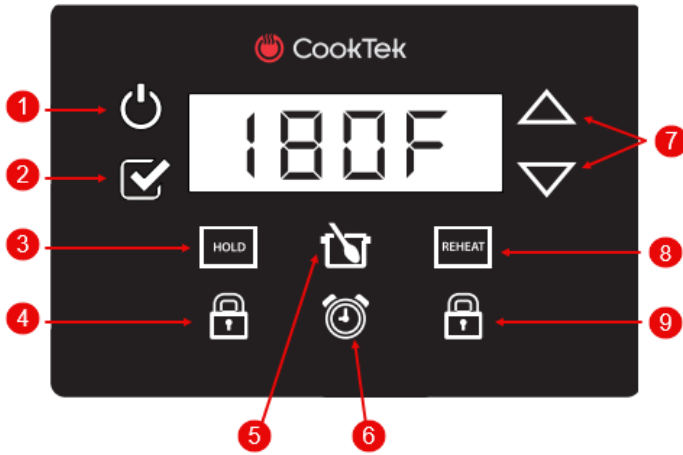

Figure 5-1: Control Box

1. **Power Icon**

When the unit is plugged in, the power icon blinks slowly until it is touched.

2. **Checkmark**

Selecting the checkmark saves setting adjustments.

3. **HOLD button**

- a. Select to set the unit to hold food at the desired temperature.

Notes:

- This will default to the last temperature saved on the unit.
- The stir timer defaults to OFF when the HOLD icon is pressed.

- b. Use the arrows (7) to make adjustments.

Note: The temperature can be adjusted in increments of 5 °F (5 °C) from 140–200 °F (60–95 °C).

- c. Select the checkmark icon (2) to save the changes.

Note: The temperature indicator blinks while the unit warms up.

4. **Hold lock icon**

Press to prevent the operator from editing the temperature while the unit is in hold mode. Hold for 3 seconds to lock and unlock.

5. **Stir icon**

Touch the Stir icon twice to turn the timer off, on, or to edit the remaining minutes. The Stir icon indicates when the operator should stir the product.

6. **Timer icon**

- Touch the Timer icon twice to turn the timer on, off, or to edit the time.
- Touch the Timer icon to view the time remaining.

7. **Temperature and timer adjustment arrows**

8. **REHEAT button**

The Reheat function uses a higher power (up to 800 watts) to rethermalize the product to the selected set temperature.

CAUTION: It is the operator’s responsibility to ensure the food is reheated to a safe temperature for consumption. The unit will not automatically detect when food is hot enough, nor will it switch to Hold mode on its own.

- a. Touch the Reheat icon.

Notes:

- The Reheat icon will default to the last temperature set on the unit.
- The stir timer defaults to OFF when the HOLD icon is pressed.

- b. Use the arrows (7) to make adjustments.

Note: The temperature can be adjusted in increments of 5 °F (5 °C) from 140–200 °F (60–95 °C).

- c. Press the Checkmark icon (2) to save the change.

5.2 4 Qt Drop-In: LED Operation

The 4-qt drop-in Soupers have three red LEDs along the top edge of the liner.

- When the unit is plugged in, the LEDs remain on for 10 seconds.
- If the tureen is removed or no longer detected, the LEDs will turn on until the tureen is reinserted and detected.
- When the tureen is placed in the liner, the LEDs flash for 5 seconds.
- If there is an error, the LEDs will flash a certain number of times corresponding to the error code and repeat until the error condition is cleared.

Example: An E-3 error causes the LEDs to flash 3 times.

6. CLEANING

Follow the steps below when cleaning your SinAqua™ Souper™. Failure to adhere to these procedures may.

1. Turn off the unit and allow it to cool.
2. If there is food in the tureen, remove and store it as required.
3. Wash the tureen in the sink using a mild soap and water. The tureen is dishwasher safe.

Note: DO NOT use abrasive cleaners on the tureen.

4. With a clean, damp cloth and mild soap, wipe the top and all sides of the Souper.

CAUTION: DO NOT splash or pour water onto the charger's control panel or into the intake/outlet vents. A shock hazard could occur, and the unit might be damaged.

Notes:

- *DO NOT immerse the Souper in water or place the unit in a dishwasher.*
- *DO NOT pour water into the chamber that is intended for the tureen.*
- *DO NOT use steel wool or abrasive cleaner.*

7. TROUBLESHOOTING

In case of a possible malfunction, your CookTek Souper™ will beep and display an error code on the alphanumeric screen. Please refer to the table below when you see an error code. To reset error conditions, press the POWER icon or unplug the unit. If an issue occurs that is not listed, contact Customer Support, call 1-800-908-8726.

Code	Error Cause	Code	Resolution
1	Broken bottom temperature sensor	E-1	Service required
2	Broken heatsink temperature sensor	E-2	Service required
3	Input line current (instantaneous rms) >10 A (240 V) or 13 A (120 V)	E-3	1. Remove power from the unit and allow it to cool completely. 2. Replace the tureen.
6	High line voltage (>264 V)	E-6	May result from power grid fluctuations and should disappear once the voltage returns to normal.
7	Low line voltage (<85 V)	E-7	May result from power grid fluctuations and should disappear once the voltage returns to normal.
8	Zero cross frequency out of range (30–80 Hz)	E-8	1. Turn the unit off, then on. 2. Plug the unit into the outlet on a different circuit breaker.
13	Dry tureen	E-13	Remove the dry tureen or press the Power icon.
16	Communication error	E-16	Reset power by pressing the Power icon.

TROUBLESHOOTING

8. NORTH AMERICA LIMITED WARRANTY: NON-PORTABLE

One (1) Year North America Limited Warranty for "Non-portable" CookTek Products. This warranty is valid in the United States of America, Canada, and Puerto Rico.

Models Covered Under this Limited Warranty

"Non-portable" CookTek products refer to all Silenzio warming buffet models, SinAqua waterless food warmer models, Incogneeto under-counter warming models, Stock Pot range models, four- and six-burner range models, Plancha models, and SinAqua Souper 4-qt, 7-qt, and 11-qt Drop-In units.

Limited Warranty

CookTek guarantees, to you, the buyer, that under normal use, the CookTek Induction System you purchased (the "Equipment") will be free from defects in materials and workmanship during the Warranty Period, according to the terms and conditions outlined here. The "Warranty Period" is fifteen (15) months from the date the Equipment is shipped from CookTek's U.S. factory or distribution center in Carrollton, Texas. This warranty relies on your prompt notification to CookTek of any claims, as explained in the paragraph titled "Warranty Claims" below, and on providing CookTek with all data and information requested by CookTek or its service agents related to such claims, as well as access to your premises and the Equipment. This warranty is valid only for the original purchaser from CookTek or its authorized dealer; it is not transferable to any subsequent buyer unless CookTek agrees to such transfer in writing.

Disclaimer of Warranties

Except as specified in the Limited Warranty above, the Equipment is provided "as-is." CookTek disclaims all other warranties, whether express, statutory, or implied, including, but not limited to, the implied warranties of title, non-infringement, merchantability, and fitness for a particular purpose. CookTek makes no guarantees that the Equipment will meet your specifications or needs. You acknowledge that you are solely responsible for choosing the Equipment and determining whether it is suitable for your needs.

Warranty Exclusions and Limitations: Improper Installation, Operation, or Maintenance

Equipment that is not installed, operated, and maintained according to CookTek's manual (as it may be updated by CookTek from time to time, the "Manual"), a copy of which is provided to you with the Equipment or otherwise will be provided upon request, is exempt from this warranty. This warranty does not cover damage or failure that, in CookTek or its service agent's sole opinion, results from failure to provide a suitable installation and operating environment (including power and HVAC) and facilities as specified in the Manual, misuse, abuse, accident, neglect, power failures or surges (over or under voltage), or damage caused by flood, fire, lightning, natural or man-made disasters, Acts of God, or from Equipment with missing or altered serial numbers.

Modifications and Repair

Equipment that has been modified or altered by anyone other than CookTek or its authorized service agents, or equipment to which non-approved devices or connection items have been attached, is not covered under this warranty. Repairing the equipment by anyone other than CookTek or its authorized service agents will void all warranties on the equipment.

Accessories

All accessories and parts (collectively "Accessories"), such as pans, bags, ceramic cooking platters, paddles, approved cleaning chemicals, and other non-electrical devices, are warranted against defects in materials and workmanship for 90 days from the date of shipment from CookTek's factory. Damage or failure of Equipment or components caused by using non-approved cleaning chemicals, devices, or processes is not covered by this warranty.

Outstanding Invoices

If the full invoiced amount for Equipment purchased has not been paid within forty-five (45) days from the invoice date, then CookTek will have no obligation to honor this or any other warranty on the Equipment until payment is received in full, including any accrued interest or other charges, has been satisfied, at which time warranty coverage will be reinstated, but the Warranty Period will not be extended.

Warranty Service, Exclusive Remedy

CookTek will be solely responsible for determining whether or not the Equipment or any component thereof is defective. Defective components covered by this warranty will be repaired or replaced at CookTek's option without charge to you and such repaired or replacement components will be covered by this warranty for the balance of the Warranty Period. Parts used in the repair of defective components and replacement components may be new, recovered or rebuilt. At its sole option, CookTek may decide to replace defective Equipment covered by this warranty with new, recovered or rebuilt Equipment of equal or greater capability, and such Equipment will be covered by this Limited Warranty for the balance of the Warranty Period. Defective Equipment and components will become the property of CookTek. This paragraph states CookTek's sole and exclusive obligation and liability and your sole and exclusive remedy under this warranty. CookTek shall not be responsible for a failure to provide warranty services due to causes beyond CookTek's or its service agents' control.

Warranty Claims

Claims under this warranty must be reported to CookTek during our normal working hours at 800.90TURBO, or such other reporting service as CookTek may designate. Upon receipt of the claim and related information and preliminary verification that the claim is valid, CookTek will promptly notify an authorized service agent to contact you and arrange for an on-site repair visit during the service agent's normal working hours. Any costs incurred by CookTek or its service agent associated with a service agent being refused or unable to gain access to the Equipment on your premises, or a claim not covered by this warranty, will be charged to you.

Disclaimer of Damages

CookTek disclaims all incidental, special and consequential damages, including but not limited to loss of use, lost revenue or profits, or substitute use, suffered by you or any third party, whether arising in contract, tort (including negligence), or otherwise, resulting from any breach by CookTek or its service agents of this warranty, or resulting from the manufacture, use, or defects, of or in the Equipment, even if CookTek was apprised of the possibility of such damages.

Customer Indemnity

You agree to indemnify, defend, and hold CookTek harmless from all third-party claims, demands, judgments, fees, and costs directly or indirectly arising out of or related to your use of the Equipment. You further agree to indemnify and hold CookTek harmless from any incidental, consequential, or special damages suffered by you, including lost revenue or profits, loss of use, or substitute use, during periods of Equipment failure or loss of use.

Governing Law, Entire Warranty

This warranty shall be governed and construed in accordance with the laws of the State of Texas, USA (except with respect to its provisions regarding conflicts of laws). The warranty described herein is the complete and only warranty for Equipment and supersedes all prior oral or written agreements and understandings that may have existed between us relating to Equipment warranties. The terms of this warranty may not be altered, amended, or modified except by a signed writing from CookTek. Any purported alteration, amendment, or modification by a service agent or anyone else will not be enforceable against CookTek.

9. NORTH AMERICA LIMITED WARRANTY: PORTABLE

Two (2) Year North America Limited Warranty for "Portable" CookTek Products. This warranty is valid in the United States of America, Canada, and Puerto Rico.

CookTek Product Models Covered Under this Limited Warranty

"Portable" CookTek products shall mean all Single and Double Burner Cooktops (countertop or built-in), Woks (countertop or built-in), FaHeaters, Soup Warmers (countertop), ThermaCube Delivery Systems, Pizza Delivery Systems, and SinAqua Souper 4-qt, 7-qt, and 11-qt countertop units.

Limited Warranty

CookTek guarantees to you, the buyer, that under normal use, the CookTek Induction System you purchased (the "Equipment") will be free from defects in material and workmanship during the Warranty Period, subject to the terms and conditions outlined here. The "Warranty Period" is twenty-seven (27) months from the date the Equipment is shipped from CookTek's U.S. factory or distribution center in Carrollton, Texas. This warranty requires you to notify CookTek promptly of any claims, as described in the paragraph titled "Warranty Claims" below, and to provide CookTek with all requested data and information related to such claims. This warranty is valid only for the original purchaser of the Equipment from CookTek or its authorized dealer; it is not transferable to any subsequent buyer unless CookTek agrees to such transfer in writing.

Disclaimer of Warranties

Except as specified in the Limited Warranty above, the Equipment is provided "as-is". CookTek disclaims all other warranties, whether express, statutory, or implied, including but not limited to implied warranties of title, non-infringement, merchantability, and fitness for a particular purpose. CookTek does not guarantee that the Equipment will meet your specifications or needs. You acknowledge that you are solely responsible for selecting the Equipment and assessing its suitability for your needs.

Warranty Exclusions and Limitations: Improper Installation, Operation or Maintenance

Equipment that is not installed, operated, and maintained according to CookTek's manual (which may be updated periodically by CookTek, the "Manual"), a copy of which is provided to you with the Equipment or will be provided upon request, is excluded from this warranty. This warranty does not cover damage or failure resulting, in CookTek's sole opinion, from failing to provide a suitable installation and operating environment (including power and HVAC) and facilities as outlined in the Manual, misuse, abuse, accident, neglect, power failure or surges (over or under voltage), or damage caused by flood, fire, lightning, or other natural or man-made disasters, Acts of God, or to Equipment with missing or altered serial numbers.

Modifications and Repair

Equipment that has been modified or altered by persons other than CookTek or its service agents, or Equipment that has had non-approved devices or connection items attached thereto, is excluded from coverage under this warranty. Repair of the Equipment by anyone other than CookTek or its authorized service agents will void all warranties on the Equipment.

Accessories

All accessories and parts (collectively "Accessories") such as pans, bags, ceramic cooking platters, paddles, approved cleaning chemicals, and other non-electrical devices are warranted against defects in materials and workmanship for a period of 90 days from the date of shipment from CookTek's factory. Failure of or damage to Equipment or components from the use of non-approved cleaning chemicals, devices or processes is excluded from this warranty.

Outstanding Invoices

If the full invoiced amount for the original Equipment purchased or for a non-returned Advance Replacement Unit has not been paid within forty-five (45) days from the invoice date, then CookTek will have no obligation to honor this or any other warranty on the Equipment until payment is received in full, including any accrued interest or other charges, has been satisfied, at which time warranty coverage will be reinstated, but the Warranty Period will not be extended.

Advance Replacement Warranty Service, Exclusive Remedy

CookTek is solely responsible for determining if the Equipment or any parts are defective. Defective equipment will be repaired only under CookTek's Advance Replacement Warranty Service. When notified of a repair issue, CookTek will send an Advance Replacement Unit to the specified address at its expense. The replacement may be new or refurbished, at CookTek's sole discretion. Upon receiving the unit, you must remove or uninstall the defective equipment and place it in the packaging provided with the replacement. You are solely responsible for packing and returning the defective equipment using the provided packaging and shipping label. Units not returned within 30 days, or improperly packaged and damaged units, will be charged to the customer at the current list price. The warranty of the Advance Replacement Unit will stay in effect until the end of your original warranty period. However, an Advance Replacement Unit does not extend the warranty duration. This paragraph outlines CookTek's sole and exclusive obligation and liability, and your sole and exclusive remedy under this warranty. CookTek is not responsible for warranty service failures caused by user non-compliance with this clause.

Warranty Claims

Claims under this warranty must be reported to CookTek during our normal working hours at 800.90TURBO, or such other reporting service as CookTek may designate. Upon receipt of the claim and related information and preliminary verification that the claim is valid, CookTek will promptly send an Advance Replacement Unit to the requested location within North America.

Disclaimer of Damages

CookTek disclaims all incidental, special, and consequential damages, including but not limited to loss of use, lost revenue or profits, or substitute use, suffered by you or any third party, whether arising in contract, tort (including negligence), or otherwise, resulting from any breach by CookTek or its service agents of this warranty, or resulting from the manufacture, use, or defects, of or in the Equipment, even if CookTek was apprised of the possibility of such damages.

Customer Indemnity

You agree to indemnify, defend, and hold CookTek harmless from all third-party claims, demands, judgments, fees, and costs directly or indirectly arising out of or related to your use of the Equipment. You further agree to indemnify and hold CookTek harmless from any incidental, consequential or special damages suffered by you, including lost revenue or profits, loss of use, or substitute use, during periods of Equipment failure or loss of use.

