

# 4 QT FREESTANDING SINAQUA™ SOUPER



## PERFORMANCE

The SinAqua™ Souper is a countertop unit from CookTek used for rethermalizing food and precision holding. Employing a forward-thinking design and high-contrast, easy-to-use capacitive touch control, the SinAqua™ Souper can take liquid foods from an unfrozen, chilled state through the food safety danger zone in as little as 45 minutes.† After rethermalization, food is held at a precise temperature within a selectable range of 140–200 °F (60–95 °C). Utilizing CookTek inductive heating technology, the SinAqua™ Souper consistently heats food without scorching and holds food twice as long as steam wells, while using less than half the energy. The SinAqua™ Souper eliminates maintenance and plumbing associated with traditional soup warmers.

†Requires stirring

## FEATURES

- SinAqua™ (waterless) holding and rethermalization
- 400 watts induction heating
- Available in brushed aluminum or powder-coated black or red (US only)
- User-selectable precision hold and rethermalization functions
- Holding temperatures range from 140–200 °F (60–95 °C)
- Rethermalizing temperatures range from 170–200 °F (75–95 °C)
- Programmable stir notification, defaults to four minutes when rethermalizing and 15 minutes when holding
- Pan compensation technology allows for use with magnetic and non-magnetic soup tureens<sup>††</sup>
- Active dry-pan protection prevents users from unintentionally damaging the unit
- Highly visible and durable capacitive touch user interface
- Audible and visual cues
- Spun aluminum exterior construction with high-gloss polycarbonate fascia and tureen liner

## STANDARD INCLUDED ACCESSORIES

- 6-ft (1.8 m) nominal plug and cord
- One 4 qt 18/8 stainless steel soup tureen and lid for maximum performance, durability, and corrosion resistance
- Two-year advanced replacement warranty (U.S. and Canada only)

## OPTIONAL ACCESSORIES

- 4 qt 18/8 stainless steel soup tureen with lid (#302478)



††The SinAqua Soupers are designed for exclusive use with CookTek-specific tureens and lids.

It is the owner and installer's responsibility to comply with all local codes. CookTek reserves the right to substitute components or change specifications without prior notice.

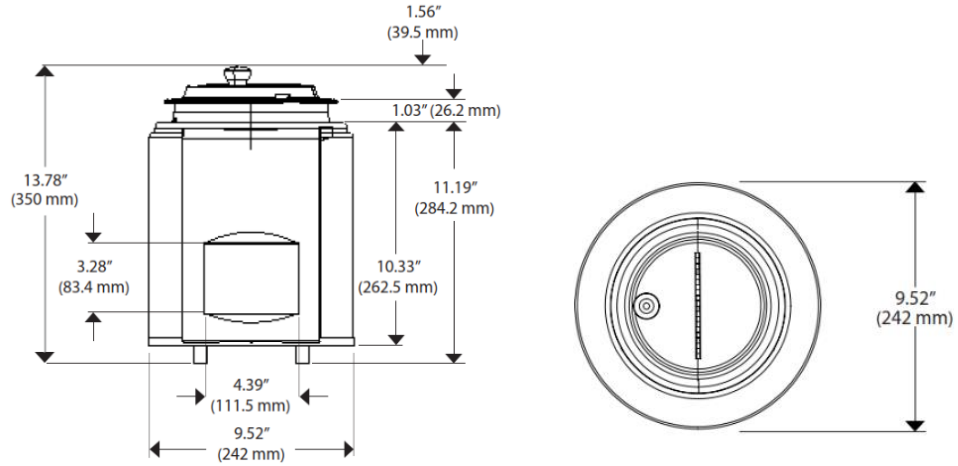

DIMENSIONS		
Unit Height	13.78"	350 mm
Width	9.52"	242 mm
Depth	10.22"	260 mm
Weight	9.50 lb	4.3 kg
Max Ambient Temperature	131 °F	55 °C

SHIPPING INFORMATION		
Packaged Height	16"	406 mm
Packaged Width	14"	356 mm
Packaged Depth	14"	356 mm
Packaged Weight	12 lb	5.4 kg
Item Class	1405001104	

ELECTRICAL SPECIFICATIONS			
UNITED STATES/CANADA			
SAS041-4	<ul style="list-style-type: none"> <li>688101-AL</li> <li>688101-BLK</li> <li>688101-RED</li> </ul>	100-120 VAC, 50/60 Hz, 4 A, 400 W	NEMA 5-15P
UK/MIDDLE EAST			
SAS042-4	688202	200-240 VAC, 50/60 Hz, 2 A, 400 W	BS1363, 13 A, 230 V
INTERNATIONAL			
SAS042-4	688203	200-240 VAC, 50/60 Hz, 2 A, 400 W	CEE 7/7 Schuko, 16 A, 250 V
AUSTRALIA			
SAS042-4	688204	200-240 VAC, 50/60 Hz, 2 A, 400 W	AS/NZS 3112:2000, 10 A, 250 V
SOUTH AFRICA			
SAS042-4	688207	200-240 VAC, 50/60 Hz, 2 A, 400 W	N/A
ISRAEL			
SAS042-4	688208	200-240 VAC, 50/60 Hz, 2 A, 400 W	SI 32, 16 A, 250 V

